

Looking for
cleanroom solutions?
Here's one of our
top performers.

everest
BioClean | anti-microbial
ceiling

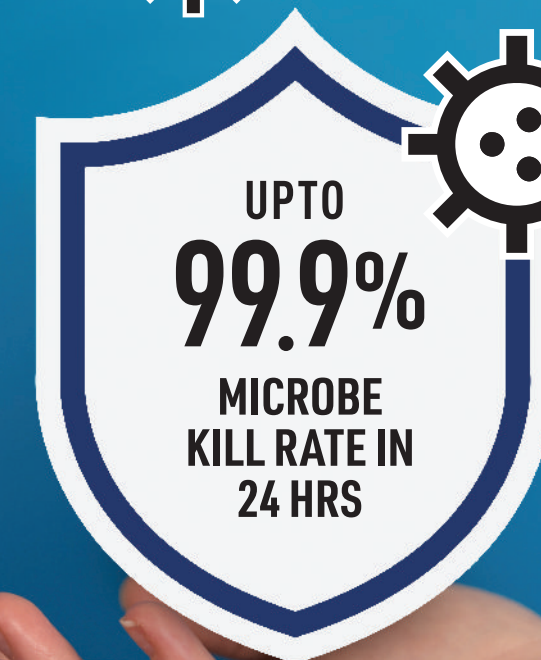
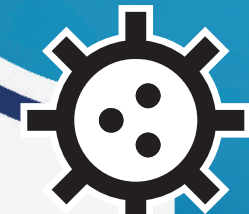
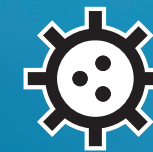

everest

EVEREST INDUSTRIES
LIMITED

everestind.com

Level 3, Tower 14, Solitaire Corporate Park,
Chakala, Andheri (E), Mumbai - 400093, India.

Email ib@everestind.com



Scan QR code
to download the
brochure



Here's why we need cleanroom solutions:

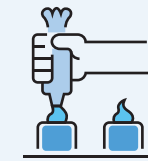

FOOD INDUSTRY

Airborne contaminants in the food processing space cause threats to health.



HEALTHCARE

Microbes in operating theatres transmit life threatening diseases to patients.



DATA CENTRES

Contamination of the air in data centers allows microbes to settle on electronic surfaces and interfere with data operations.



PHARMA LABS

Spoilage cost increases when drugs fail to pass quality tests due to microbial contaminants.

Presenting a unique cleanroom solution.

Everest BioClean is a complete, maintenance-free ceiling solution for cleanroom applications. Along with its incredible, antimicrobial performance, it is an ideal product for critical spaces where bacterial, mold, fungal, or microbial activities are evident.

With the strength of cement as its base material, BioClean shows superior performance in comparison to any other mineral fibre, calcium silicate or any other cleanroom ceilings.

PRODUCT BENEFITS



ANTI-MICROBIAL PROPERTIES

Blocks the growth of infectious microbial colonies on ceilings.



10 YEAR WARRANTY

On anti-microbial and anti-sagging property.

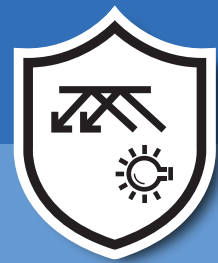

HIGH LIGHT REFLECTANCE

Increases visibility and creates a 93% brighter space to work in.



ISO 4 CERTIFIED

Class 10 - ensures lesser particulate emission.

SUPERIOR ATTRIBUTES

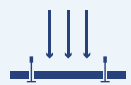

SAG RESISTANT



EASY TO CLEAN



FIRE RESISTANT



RH99 HUMIDITY RESISTANT



UPTO 99.9% MICROBE KILL RATE IN 24 HOURS

PHYSICAL AND TECHNICAL SPECIFICATIONS

Standard Sizes	595 x 595mm	Reaction to Fire (R2F)	Class A
Thickness	6mm	Modulus of Rupture	>10 MPa
Edge Profile	Square Edge	Microbe Kill Rate	Upto 99.9% in 24 hours
Light Reflection LR	>93%	Thermal Conductivity	0.21 W/mK
Sag Resistant	+/-1 mm deflection per tile from normal at equilibrium	Humidity Resistance	99%RH

GRID SYSTEM & KEY COMPONENTS

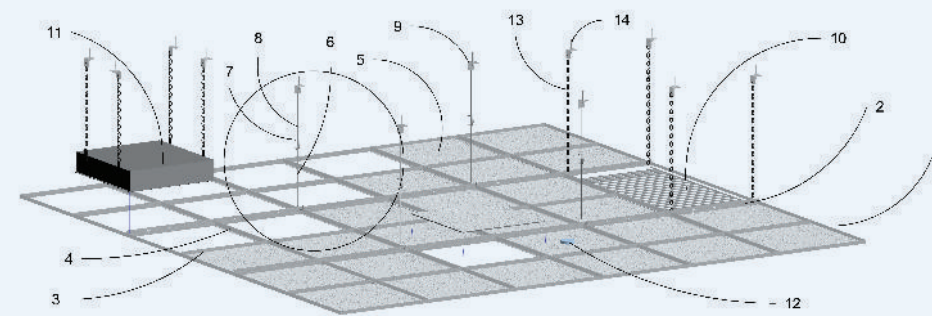

- 1 Wall Angle
- 2 Main Tee
- 3 Cross Tee 600
- 4 Cross Tee 1200
- 5 BioClean Ceiling Tile
- 6 J Hook
- 7 Butterfly Clip
- 8 Wire Rod
- 9 Soffit Cleat
- 10 AC Grill
- 11 LED Light
- 12 Smoke Detector
- 13 Chain for Fixture Support
- 14 Anchor Fastener

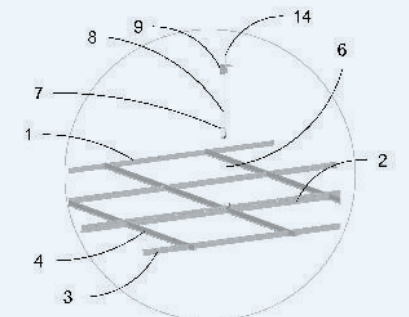

PRODUCT ADVANTAGES

PROPERTY	EVEREST BIOCLEAN	OTHER CLEANROOM CEILING SOLUTION
Clean Room Certification	ISO 4 (Class 10 - 10 times lesser particulate emission than Class 100)	ISO 5 (Class 100)
Light Reflectance	>93%	75-90%
Sag Resistant	Yes	No
Suitable for Semi-Exposed Area	Yes	No



Application areas

PHARMACEUTICAL PLANTS

HOSPITALS

LABORATORIES

DATA CENTERS OR SERVER ROOMS

FOOD INDUSTRY

HEPA FILTER UTILIZING SPACES

MANUFACTURING UNITS

AUTOMOTIVE

ELECTRONICS

AEROSPACE



EXPERT SUPPORT

The Everest project team provides expert support services throughout all stages of any construction project, including:

- Technical advice
- Supply of data sheets and certification
- Product selection and application consultation
- Site visits and on-site training
- Installation advice